

**Illinois Chapter of the
National Association of Telecommunications
Officers and Advisors (ILNATOA)**

Delivery of PEG Programming at Commercial Quality

September 2, 2008



Columbia Telecommunications Corporation • 10613 Concord Street • Kensington, MD 20895
301.933.1488 • www.CTCnet.us

Table of Contents

1	Overview and Methodology	3
2	Encoding of PEG Video.....	4
3	Transport of PEG Video	5
4	Insertion of PEG Video into the AT&T Programming Lineup	6
5	Transmission of AT&T Programming to Viewers	7
6	Summary	9

Table of Figures

Figure 1: PEG Origination Uplink.....	5
Figure 2: PEG Channel “Insertion”	6
Figure 3: IP Video Delivery to Subscribers.....	8

1 Overview and Methodology

The purpose of this report is to determine whether public, educational and government (PEG) programming over the AT&T video system can be delivered with comparable quality and functionality to those of commercial channels.

Whether the programming source for a video channel is a PEG studio, an off-air broadcast, or a commercial network satellite downlink, a systemic disparity in delivery quality between PEG and commercial channels results from dissimilar technologies or configurations employed for these two categories of services – there is no fundamental technical difference between a video signal with commercial advertisements and one without.

Furthermore, one of the key advantages to a fully Internet Protocol (IP) based video delivery network is the ability to provide a virtually limitless quantity of video channels with control over access and viewer experience at a level of granularity down to the individual subscriber, or any broader subset. This can include anything from unique channel line-ups to customized on-screen advertisements.

The primary strategy we recommend for achieving comparable quality and functionality for PEG program delivery is to replace or reconfigure systems and components currently used for PEG delivery with components and configurations equivalent to those used for commercial channels. This recommendation is necessary to address technical limitations in the design of the current AT&T PEG solution to the extent that they contribute to the degraded quality, functionality, and presentation of these channels.

Much of the detailed information about the specific design and operation of the AT&T system has not been made publicly available. Where there is not sufficient detailed technical information available to specify particular configurations or components, this document refers to the capabilities of systems successfully providing similar Internet Protocol (IP) based video delivery functionality.

This document separates the discussion of delivery and presentation of the PEG channels into four separate functional components:

- Encoding (conversion) of PEG video to an IP digital format
- Transmission of signal from the PEG center to AT&T's system
- Insertion of PEG signals into AT&T programming lineup
- Transmission of PEG programming to AT&T customers

Note that the discussion of “video quality” in this document relates only to the upper limit possible from the current systems used to carry PEG signals on the AT&T network, which is not affected by the quality of recorded content or studio systems comprising the PEG source material. Whether for a commercial or PEG channel, we recognize that the diagnosis and resolution of isolated video quality problems is complex and not always caused by the subscriber delivery network.

2 Encoding of PEG Video

PEG channels can be encoded at the same quality as commercial channels.

One of the most significant factors determining the quality of the PEG signal is the technical format used for encoding and compressing the PEG origination signals. The encoding format must be selected so that the picture resolution, color, motion reproduction, and other observable features of the programming are not noticeably changed by the process. Depending on the format of the programming material at the PEG source, which ranges from analog video to uncompressed digital streams, this encoding step may involve an initial conversion of the signal to a digital format (digitization) or changing the signal to a different digital format (transcoding). Regardless, according to AT&T specifications, the net result is a digitally compressed signal leveraging the Windows Media Video 9 (WMV 9) format, currently using a total encoding data rate (video and audio) of 1.25 Mbps¹.

It is not known exactly what encoding or transcoding equipment is used for commercial channels carried on the AT&T system. The typical studio environment for standard definition broadcast television uses the serial digital interface (SDI) standard with D1 screen resolution or (720 x 480), though many digital encoding processes in a typical studio environment use resolutions of 640 x 480, as it effectively reproduces the 4:3 aspect ratio of standard definition video. Using lower resolution encoding will result in a degraded picture. This is evident when an NTSC program is recorded to a VHS video tape.

Therefore, the recommended approach is to encode PEG origination signals at a resolution of 640 x 480 (or 720 x 480), equivalent to that of a typical professional standard definition studio environment. A wide range of products exist that support WMV 9 encoding at a range of bit rates, frame rates, and resolutions. For example, the Inlet Technologies Spinnaker 3005 (recommended by AT&T²), and the VBrick WM Appliance will both support WMV 9 Main Profile encoding at bit rates at or above 4 Mbps.

Most encoders have selectable resolution, buffering, output bandwidth and other parameters. Again, the ideal approach would be to select settings and equipment that have been demonstrated to provide the quality of the commercial programs.

¹ AT&T provides supported encoding specifications in their "PEG Equipment & Transport Information" version 7 document

² The Inlet Spinnaker 3005 is an encoding appliance specifically identified by AT&T in their "PEG Equipment & Transport Information" version 7 document.

3 Transport of PEG Video

Technology to preserve the quality of PEG audio and video signals while in transit to the AT&T network is readily available.

Once the video is encoded into a digital format suitable for IP-based transmission, it is transported to AT&T's system, either over dedicated data circuits or the Internet (Figure 1). It is important that the capacity and quality of the entire link between the PEG origination location and the point of "insertion" into the AT&T video distribution systems preserves the quality of the video signal. No matter what technology is used, the link used to transport the video must be of sufficient bandwidth to accommodate the video created by the encoder—the capacity requirement is dictated by the encoding.

Figure 1: PEG Origination Uplink

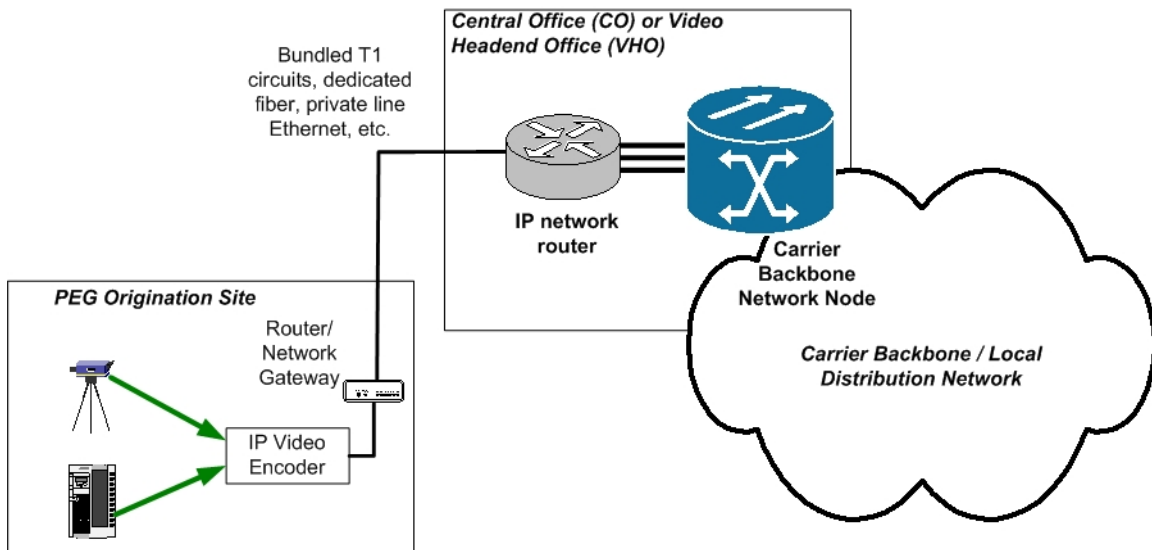

In other words, if the encoder generates a video stream of 3 megabits per second (Mbps) when it is configured for the necessary resolution and quality, then the link must have more than 3 Mbps available at all times for each video link. There are many strategies to guarantee that the transmission link preserves picture quality. One is to establish a dedicated circuit of sufficient capacity from the origination point to the video headend. This is a technique commonly used by cable operators and also by Verizon in its video systems. Other techniques include using "quality of service" (QoS) mechanisms that prioritize certain types of traffic, including video, relative to other traffic to ensure that sufficient capacity remains available even when multipurpose backbone links are heavily saturated.

4 Insertion of PEG Video into the AT&T Programming Lineup

PEG channels need not be inserted into the program lineup in a manner different from commercial channels.

Insertion of video programming into an IP-based delivery system is fundamentally different than a traditional cable system. A traditional cable signal physically “inserts” signals by modulating onto various carrier frequencies and combining these modulated signals. An IP delivery system only re-transmits the encoded origination signal, either in its native format or a transcoded version in which the type of encoding, bit rate, or other parameter is modified prior to re-transmitting to subscribers. Typically video broadcast servers are used to generate individual streams for each user, or the server can transmit a single multicast stream (discussed further in Section 5).

Figure 2: PEG Channel “Insertion”

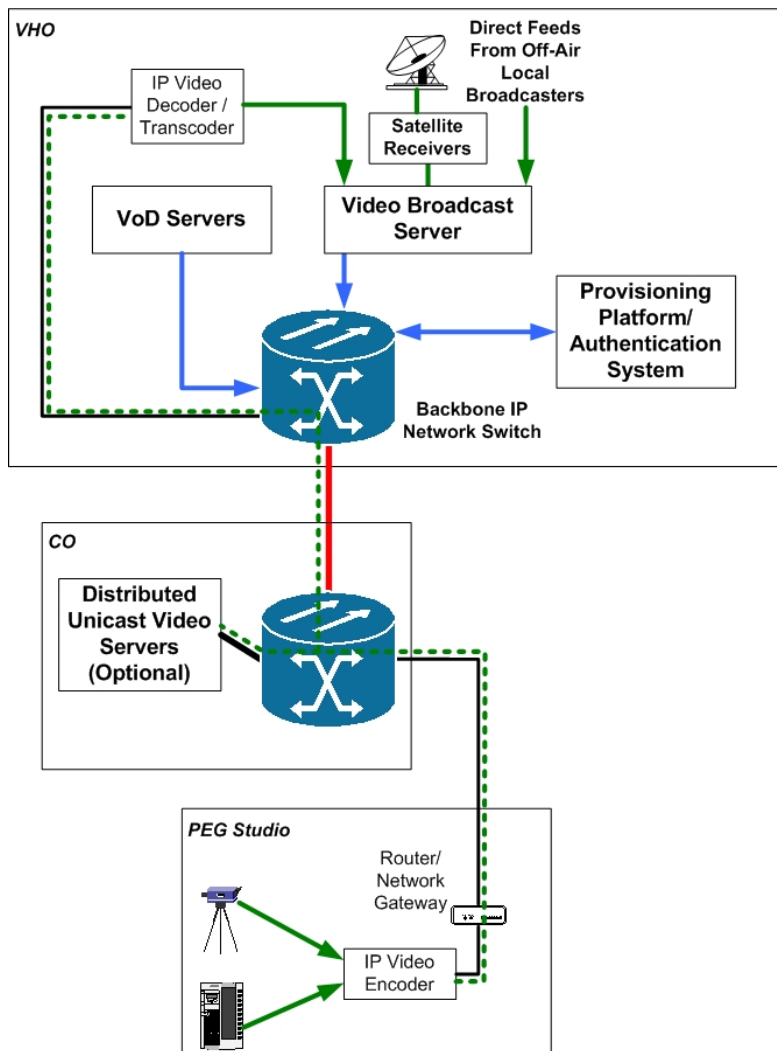

In order to preserve picture quality, the PEG programming must be available to the AT&T broadcast servers in the same manner that the commercial programs are available.

Generally, in IP video systems, these broadcast video servers receive streams from their sources (studios, satellite downlinks, antenna feeds) and “host” the available channels in the same manner that Internet Web sites host the content on their sites. Parameters on the server should be set so that the PEG programming is treated in the same manner as commercial programming.

5 Transmission of AT&T Programming to Viewers

IP-based video technologies offer greater flexibility to localize channel lineups, not less.

Video delivery systems built entirely on IP-based transmission, including AT&T’s U-verse, are organized differently from traditional cable systems. In a traditional cable system, the programming channels are “combined” into a channel lineup and sent in a cable to the subscribers. Any change to the channel line-up downstream of this insertion involves a physical process of filtering and inserting a new signal in a particular (physical) channel. The channel number indicates the placement of the programming in frequency (in analog systems) or the location in the cable channel lineup where the set-top converter knows to find the signal.

In an IP system, the programming is streamed from network servers at the video headend, or at some intermediate location, and the viewer selects the programming from their set-top converter. The server at the headend then streams the requested program to the set-top box. Each viewer receives exactly one discrete video signal corresponding to the channel requested. This model is more analogous to a “unicast” delivery in response to a request for a web page from a web browser. This differs from traditional cable services, in which all channels are physically broadcast and delivered to every viewer simultaneously – the television or set-top box only displays the “tuned” channel in this case. There is no concept of physical “channels” in an IP video delivery system.

Figure 3: IP Video Delivery to Subscribers

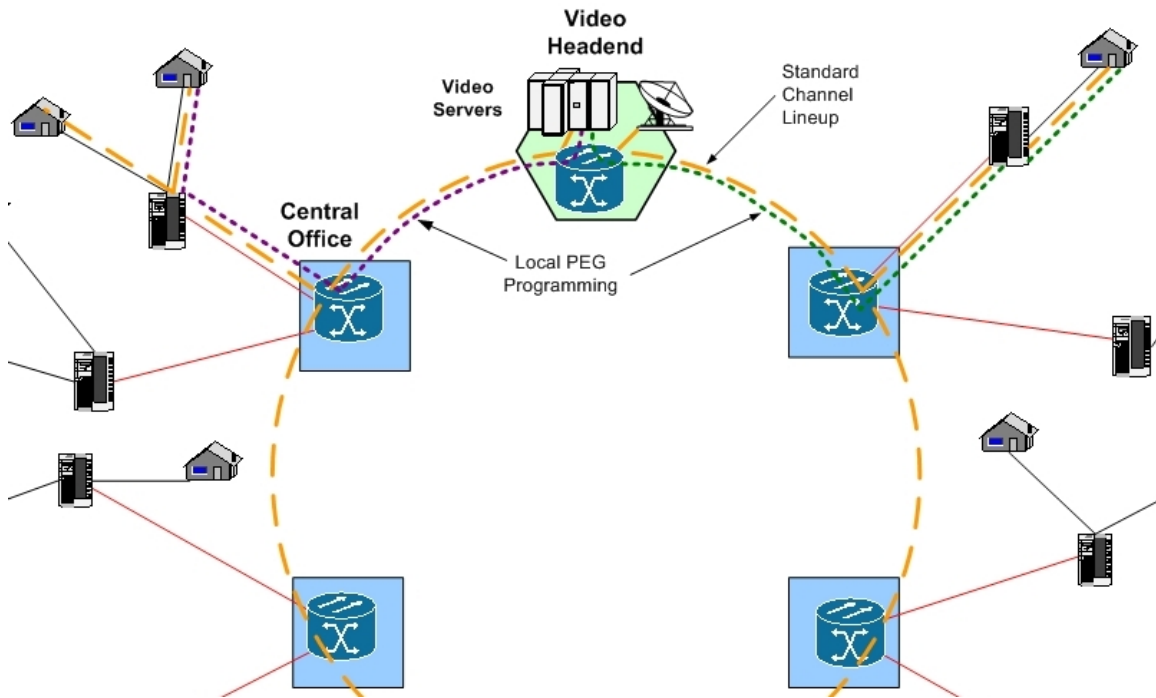

The benefit of IP-based video delivery is further realized relative to the ability to localize channel line-ups. Through the use of IP multicast technology, the network devices (switches and routers) downstream of the servers can make “copies” of the video streams on an as-needed basis, while filtering or “pruning” streams not “requested” by set-top boxes within portions of the network to reduce overall network capacity required. This creates highly deterministic capacity demand over local and backbone segments of the network, not impacted by the total number of “channels” available to subscribers. Even without the use of multicasting, distributed IP video broadcast servers can provide the same effective result from a network access and capacity perspective, bringing the ability to serve “unicast” copies of individual streams to viewers closer to the edges of the network (at least down to the Central Office level). Moreover, since only the channels requested by the set-top box will be streamed, the ability to support nearly unlimited quantity of channels either in a centralized or distributed architecture exists.

Which channels can be requested by a set-top box is determined strictly by access policies associated with the unique authentication and provisioning of each unit. Provisioning of set-top boxes involves the conditional enforcement of access policies by authentication systems that perform lookups on one or more databases of subscriber information. These databases map technical set-top box identification to subscriber information, such as the subscribed service package and billing status. Based on this provisioning, it would be possible to filter, or conditionally populate the “channels” listed in the interactive program guide to only include those channels to which a customer subscribes.

In other words, since the network relies on the ability to uniquely address and control each set-top box, it is possible to generate a custom channel line-up and numbering scheme for any subset of subscribers. Just as “premium” on-demand content is billed on an individual subscriber basis, the access to PEG channels can be individually controlled and authorized. In the case of PEG, this may mean that a different group of channels are listed in the program guide, of which each point to different video server stream addresses (channels), depending upon some particular field within the authentication/provisioning database relating to location. For example, it would be feasible to create a custom channel lineup associated with the billing zip code for a particular set-top box. Note that this would not be true in a traditional cable system, even with interactive addressable set-top boxes, since the flexibility to create custom line-ups is ultimately limited by the number of channels supported within the capacity of the subscriber connection.

Therefore, flexibility in channel lineup control and quantity of channels is increased because of AT&T’s IP-based architecture, rather than it being a limiting factor. Despite having more centralized core systems supporting larger geographic areas than with a traditional cable system, an IP-based delivery system does not require delivering all channels to all locations. As mentioned, regardless of the number of channels, only those “requested” by the set-top box are transmitted to the viewer. Channels are essentially addresses within an IP-based server architecture (i.e. a web address, or URL); a channel in an IP-based delivery system does not represent a specific frequency space or constant amount of capacity between the provider and the subscriber, as in a traditional cable system.

6 Summary

It is technologically possible to deliver public, educational, and government (PEG) programming over the AT&T video system with comparable quality and functionality to the commercial channels. Moreover, in the State of Illinois, it is a statutory requirement for any operator of cable television or video programming services³.

This report has reached that conclusion based on the following findings:

- PEG channels can be encoded at the same quality as commercial channels;
- Technology to preserve the quality of PEG audio and video signals while in transit to the AT&T network is readily available;
- PEG channels need not be inserted into the program lineup in a manner different from commercial channels; and
- IP-based video technologies offer greater, not less, flexibility to localize channel line ups.

³State of Illinois Cable and Video Competition Law of 2007, 220 ILCS 5/21-601(c)